



Safe Harbor Statement

Certain statements and projections contained in this presentation are, by their nature, forward-looking within the meaning of the Private Securities Litigation Reform Act of 1995. These forward-looking statements are based on our current expectations, estimates and projections about our industry and business, management's beliefs, and certain assumptions made by us, all of which are subject to change. Forward-looking statements can often be identified by words such as "anticipates," "expects," "intends," "plans," "predicts," "believes," "seeks," "estimates," "may," "will," "should," "would," "could," "potential," "continue," "ongoing," similar expressions, and variations or negatives of these words. These forward-looking statements are not guarantees of future results and are subject to risks, uncertainties and assumptions that could cause our actual results to differ materially and adversely from those expressed in any forward-looking statement. Dana's Annual Report on Form 10-K, subsequent Quarterly Reports on Form 10-Q, recent Current Reports on Form 8-K, and other Securities and Exchange Commission filings discuss important risk factors that could affect our business, results of operations and financial condition. The forward-looking statements in this presentation speak only as of this date. Dana does not undertake any obligation to revise or update publicly any forward-looking statement for any reason.





Dana Snapshot

Founded in **1904**



2018 preliminary sales:
\$8.1 billion



~30,000
people



21
technical centers



136 major facilities

33 countries

6 continents

143 customers in
countries



Business Overview

Markets

Light Vehicles



51%

Heavy Vehicles



28%

Off-Highway



21%

Segments

Light Vehicle Driveline Technologies

40%



Commercial Vehicle Driveline Technologies

27%



Off-Highway Drive and Motion Technologies

21%



Power Technologies

12%



Regions

North America

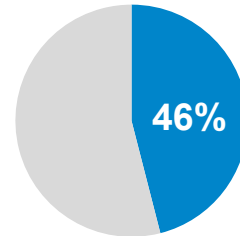

Europe

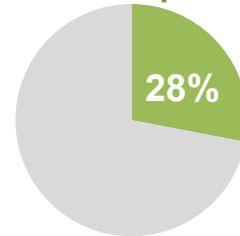

South America

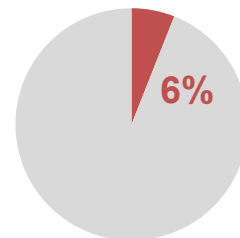

Asia Pacific

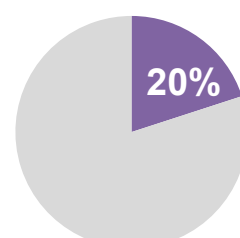

Technologies



Drive

Axles, driveshafts, transmissions, hydraulic wheel and track drives, drive units for electric and hybrid vehicles



Motion

Winches, slew drives, planetary gearboxes, hydraulic pumps, motors and valves, electronic controls



Electrodynamic

e-Motors, generators, power electronics, controls and software



Thermal

Transmission and engine oil cooling, battery and electronics cooling, charge air cooling, and exhaust-gas and heat recovery



Sealing

Gaskets and seals, transmission separator plates, cam covers and oil pan modules, heat shields, and fuel cell plates



Digital

Active and passive system controls, Software as a Service including descriptive and predictive analytics



4
Global
Locations



2
Engineering
Centers



2019T Sales:
~\$30M
Purchase Price:
\$88M

Manufacturing
in Europe and China



SMARTMOTION CONTROLLERS™
POWERED BY TAU SOFTWARE

TAUTRONIC CONTROLLERS™
POWERED BY TAU SOFTWARE

SCHWARZMÜLLER INVERTERS™
POWERED BY PLUS1 SOFTWARE

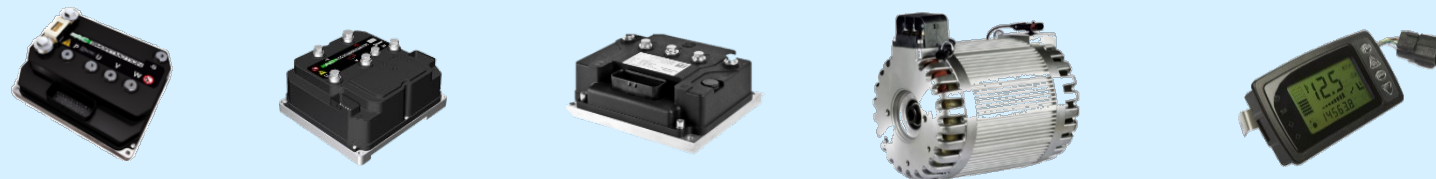

A Leader in Low Voltage Electrodynamic Components

Sales by End Market

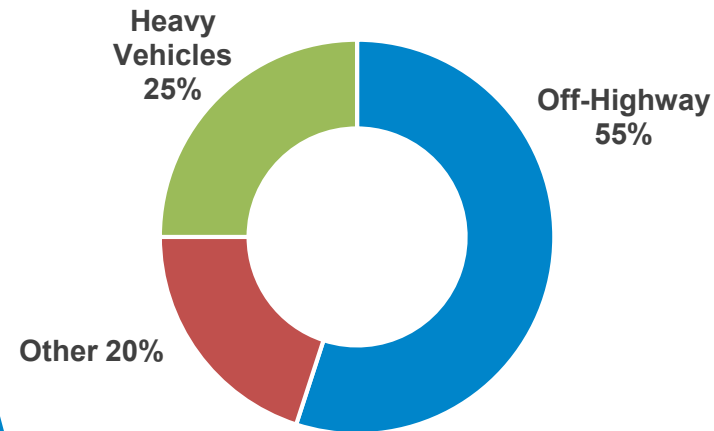

Sales by Region

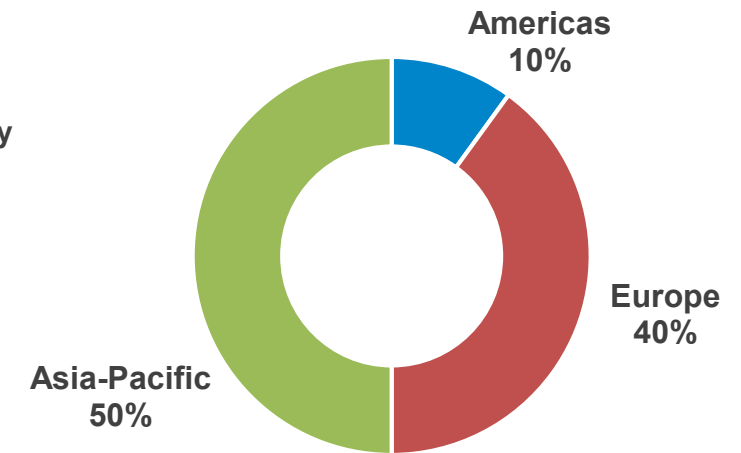

Key Customers















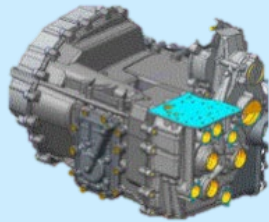

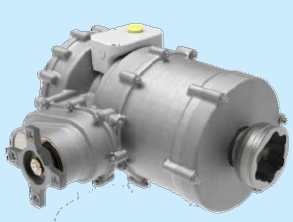

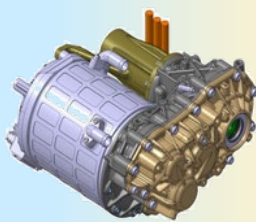



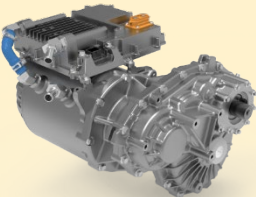

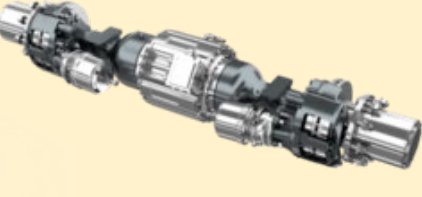



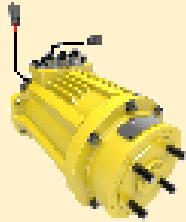

e-Propulsion Product Portfolio



Technology Solutions

Mild hybrid	Primary Axle Hybrid Drive (P/HEV)			Battery Electric Vehicle (BEV)			
Power Electronics	Hybrid Drive Unit	Hybrid Axle	Independent e-Axle	Direct Drive	e-Drive Unit	Rigid e-Axle	Wheel Drives
  	 	 	 	  	 	 	   

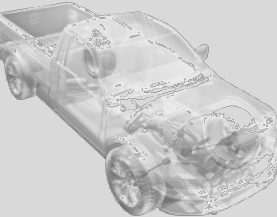
Vehicle Applications

Recreational	Utility	Passenger Car	Material Handling	City Delivery	Light Truck	Medium Duty	Heavy Duty/Bus	Mining Truck
 <p>Club Car</p>	 <p>Taylor Dunn</p>	 <p>Bolloré Blue Car</p>	 <p>BYD 1.6T & 2.5T</p>	 <p>Zenith Electric Van</p>	 <p>[Under Development]</p>	 <p>Workhorse</p>	 <p>Karsan ATAK midibus</p>	 <p>Sandvik DD422iE</p>



e-Propulsion Content Growth

Full-Frame Light Trucks

ICE



>2x
CPV

Electric

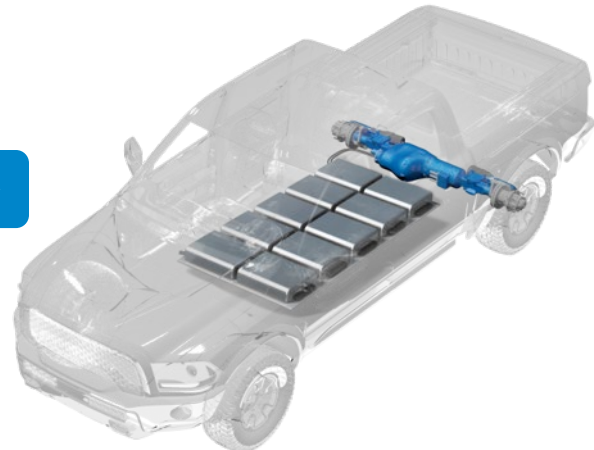

Medium-Duty Trucks

>2x
CPV

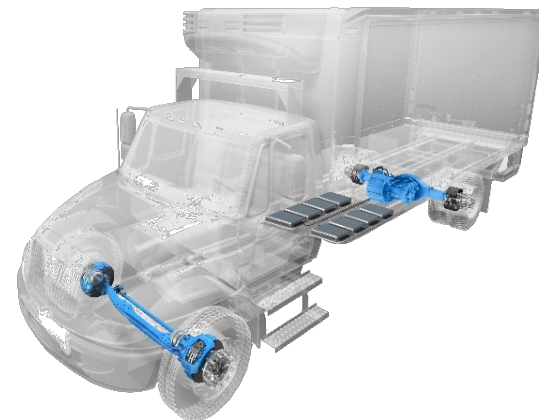

Off-Highway Equipment

≈
CPV

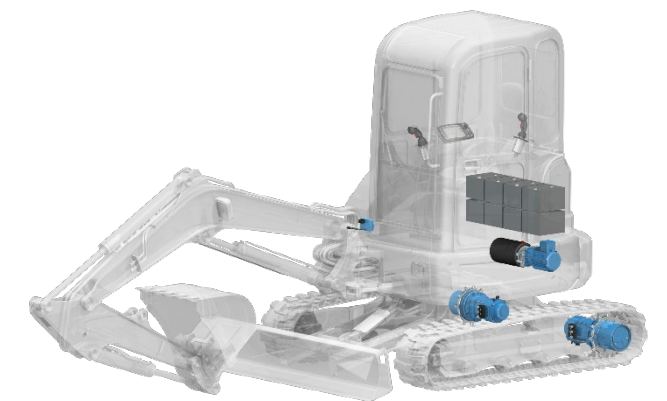
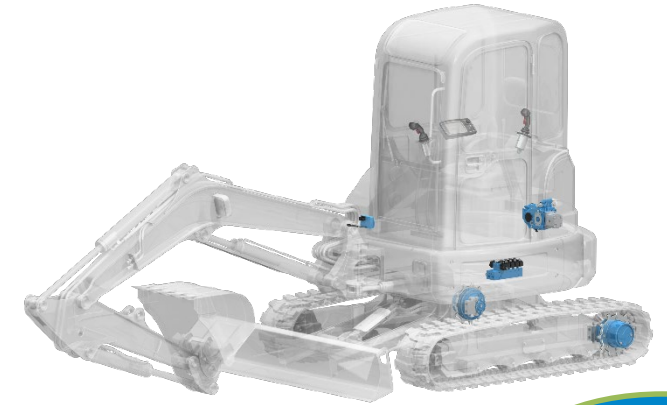

Significant content per vehicle expansion opportunity



e-Propulsion Market Outlook

Full-Frame Light Trucks

Medium-Duty Trucks

Off-Highway Equipment*

2018

2025

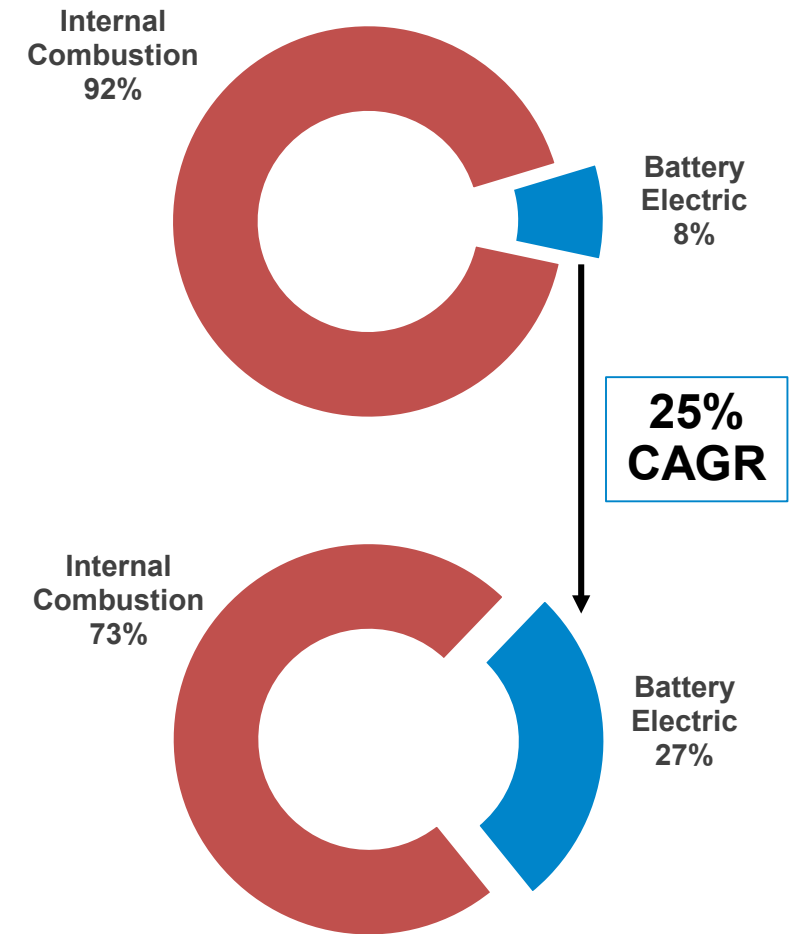
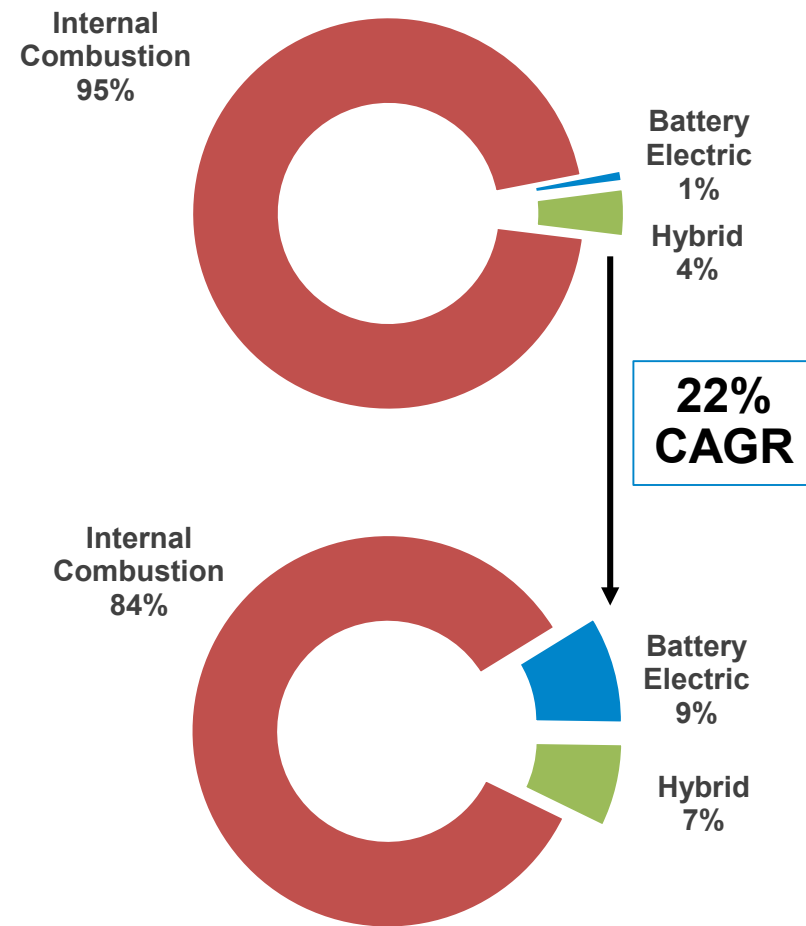
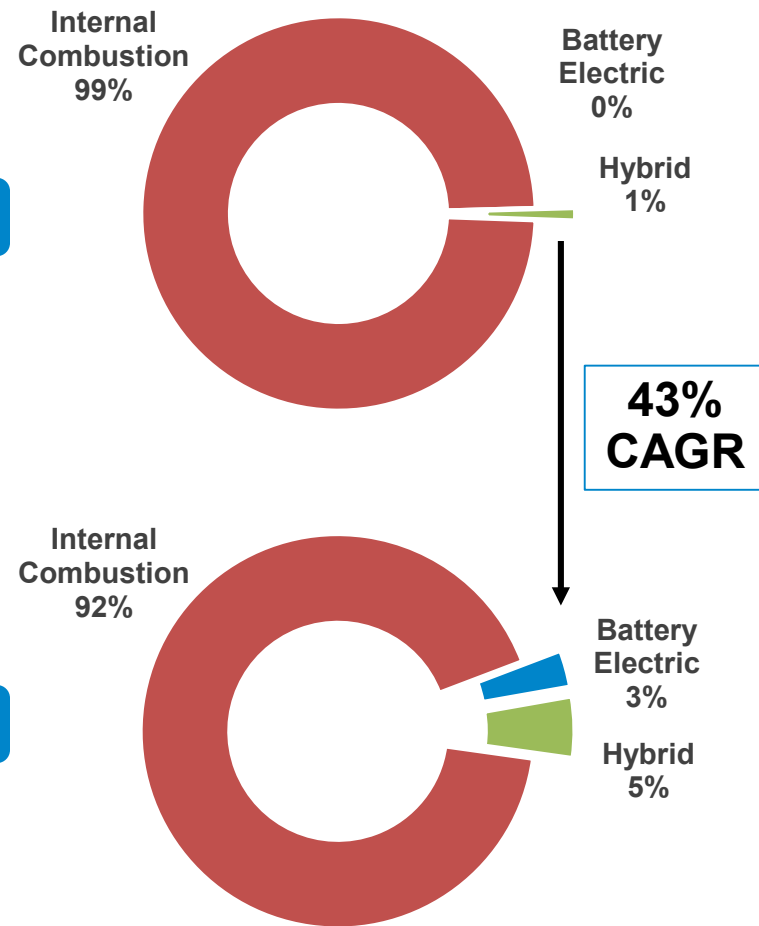

All segments offer attractive market growth



Spicer Axles Driving the Future



Light Vehicle Ultra-Efficient AdvanTEK® Axle System

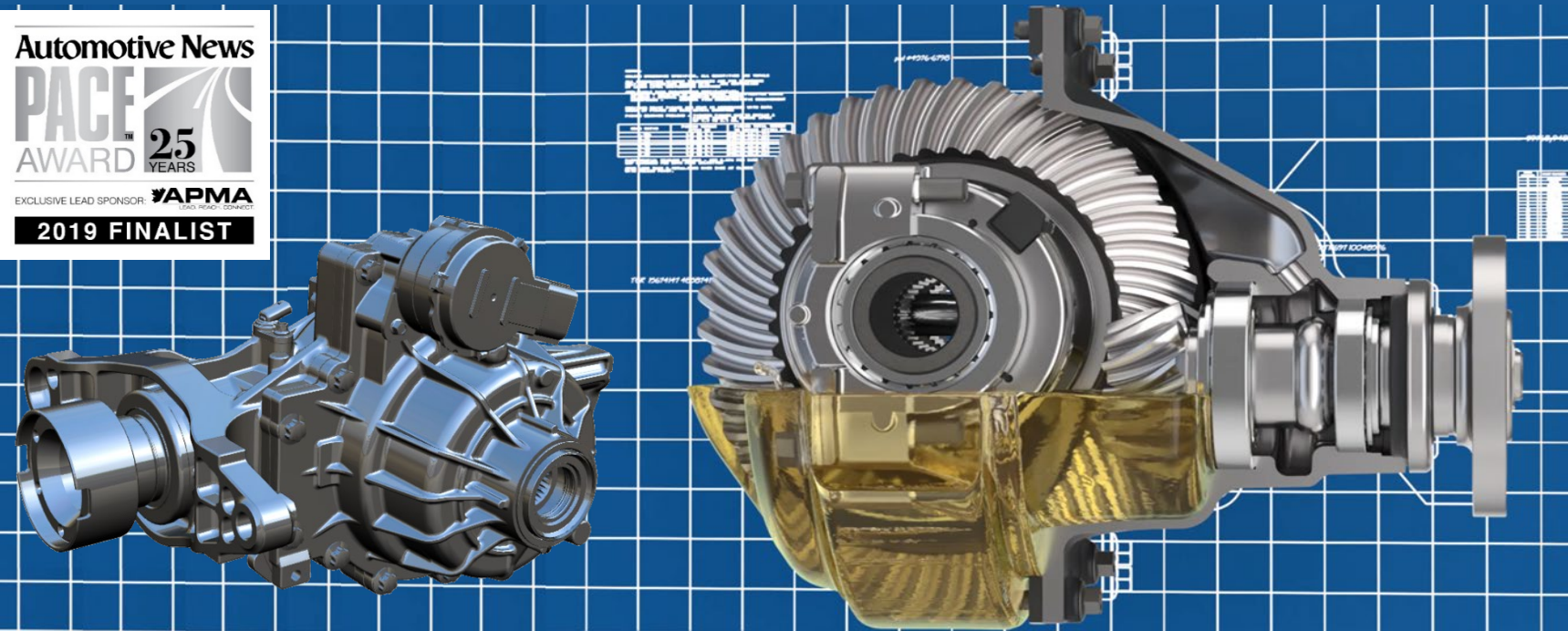

Delivers **~2% improvement** in fuel economy to the end consumer



The **most efficient axle** for automotive applications – a full **30% better** than current best-in-class competitive products

Commercial Vehicle HD Single AdvanTEK® Axle System

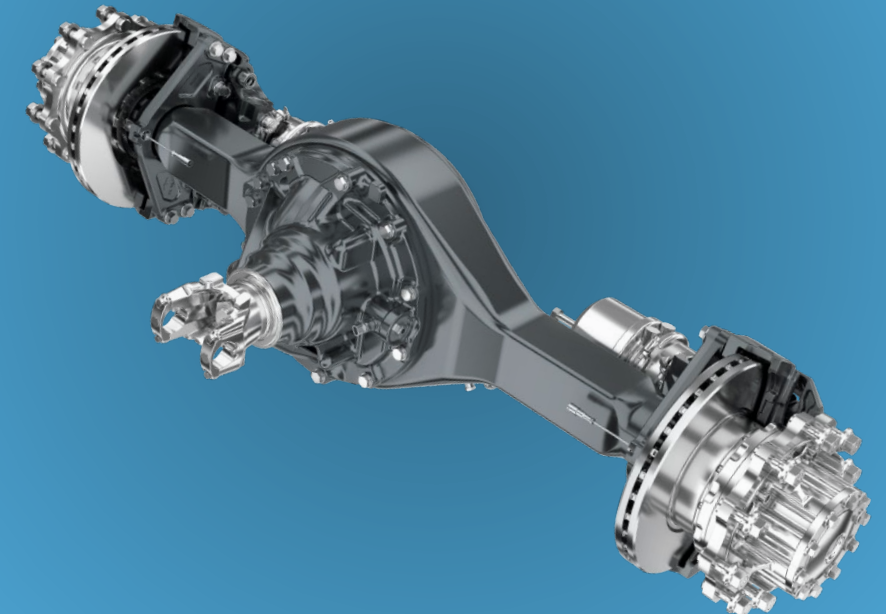

Provides **60 pounds** of weight savings

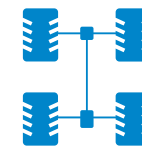

Application in **4x2, 6x2, and 6x4** vehicle configurations



Driving Growth



Industry-leading **technology** powering growth



Significant **new business** wins in all segments

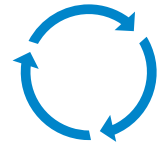

Multiple end markets provides **cycle stability**



Investing for the **future of mobility**





2015 to 2018 Performance Improvement

SALES

~\$2.0

billion

↑ 33%

Adj. EBITDA

~\$300

million

↑ 47%

Free Cash Flow

~\$100

million

↑ 64%

Diluted Adjusted
Earnings Per Share

~\$1.15

↑ 67%

Outstanding performance, outstanding future...



Outlook and Financials

Jonathan Collins

Executive Vice President and Chief Financial Officer



2018 Preliminary Results



- » Sales surpassed high end of guidance range as Q4 demand exceeded expectations; however, conversion on the incremental sales was negligible as premium costs to fill the orders offset the added contribution margin and product mix was unfavorable
- » Adjusted EBITDA landed near low end of guidance range, ~\$8M lower than prior indication primarily due to increased commodity costs
- » Free cash flow results are in line with prior expectation at ~3.0% margin

Key Financial Metrics

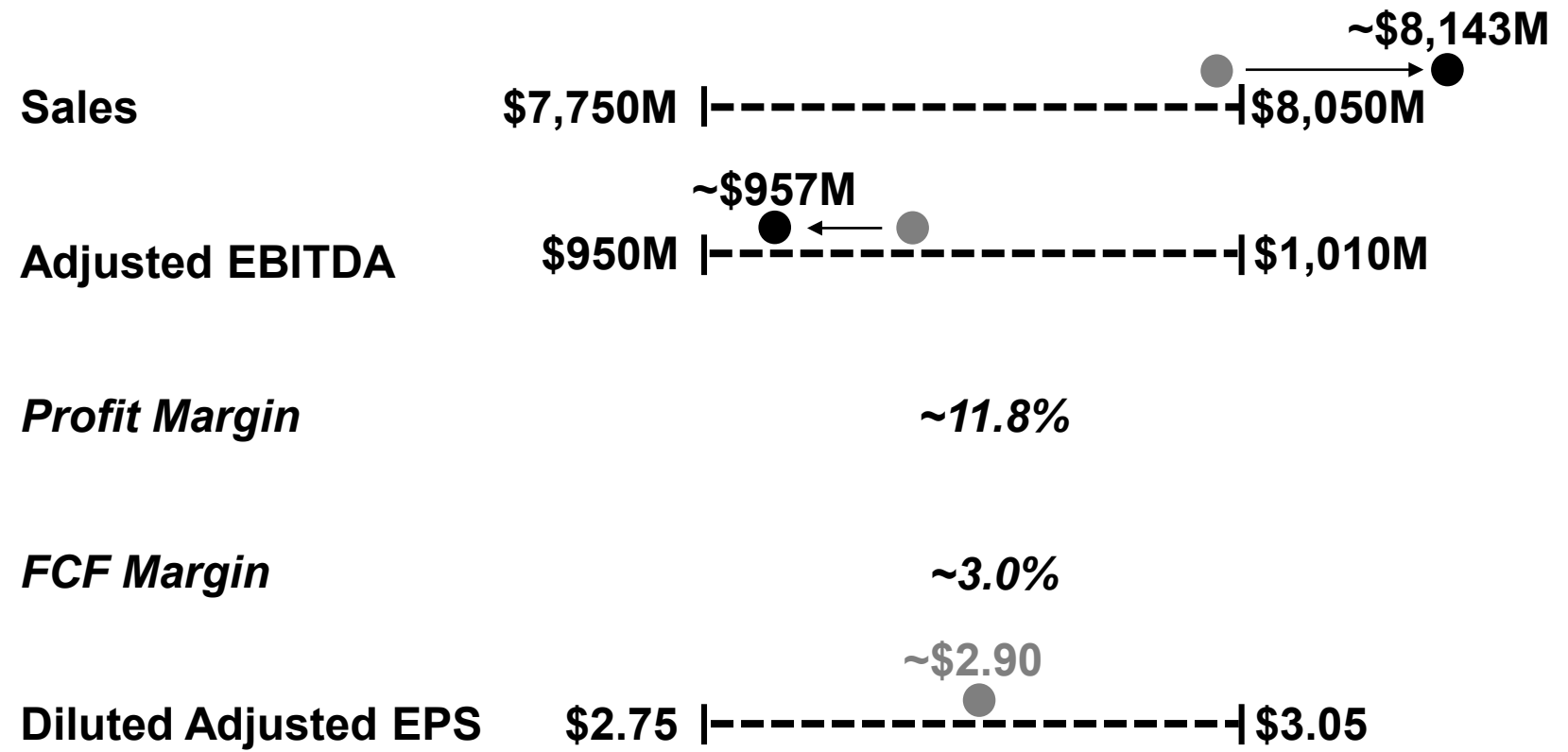

Delivering preliminary results within range of expectations

See appendix for comments regarding the presentation of non-GAAP measures

--- Guidance range ● Preliminary Result ● Prior Indication





2018 Preliminary Sales and Profit Changes

- » Sales growth of 13% compared with last year driven by conversion of backlog, improving end-market demand, a full year of the 2017 acquisitions, and recovery of commodity inflation
- » ~85 bps of margin expansion as a result of organic and inorganic growth was largely offset by ~65 bps margin headwind due to commodity cost increases, net of recoveries
- » In addition to ~\$110M of commodity cost increases, Section 232 and 301 tariffs increasing costs by ~\$10M with minimal commercial recovery

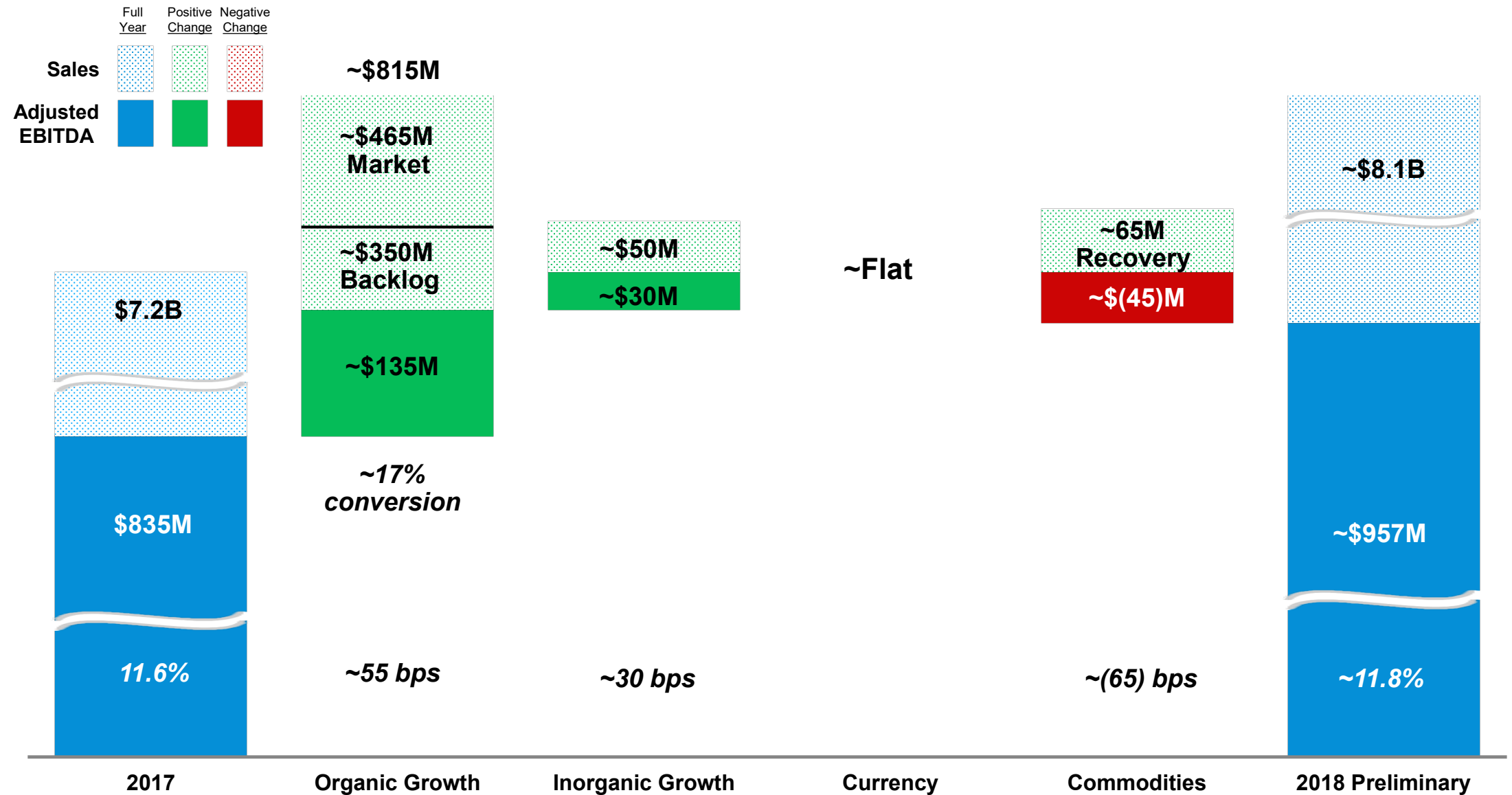

Delivered >\$900M of sales growth and added \$120M of profit

See appendix for comments regarding the presentation of non-GAAP measures





2019 – 2021 Sales Backlog: \$700 Million

- Backlog includes booked incremental new business net of any lost replacement business
- Backlog is incremental to 2018 sales holding both foreign currency exchange rates and vehicle production volumes constant
- Delivering positive backlog in all business units across all major customers and regions

\$ in Millions

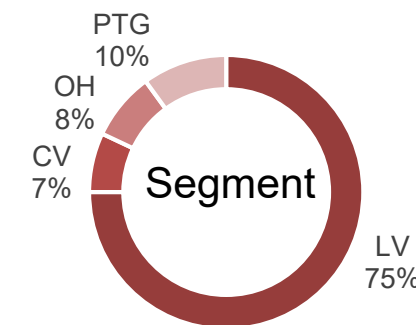
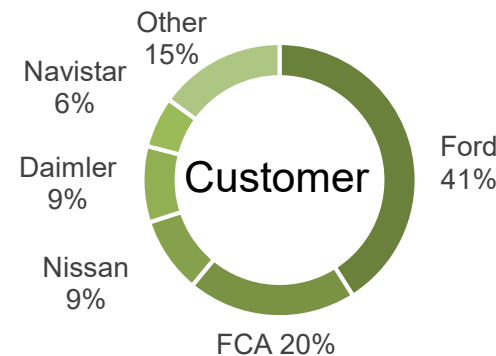
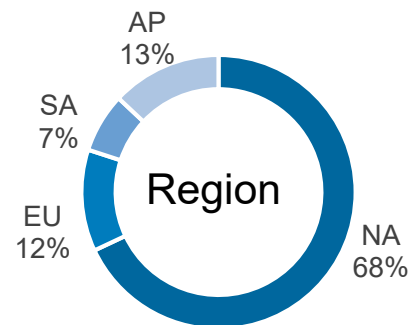
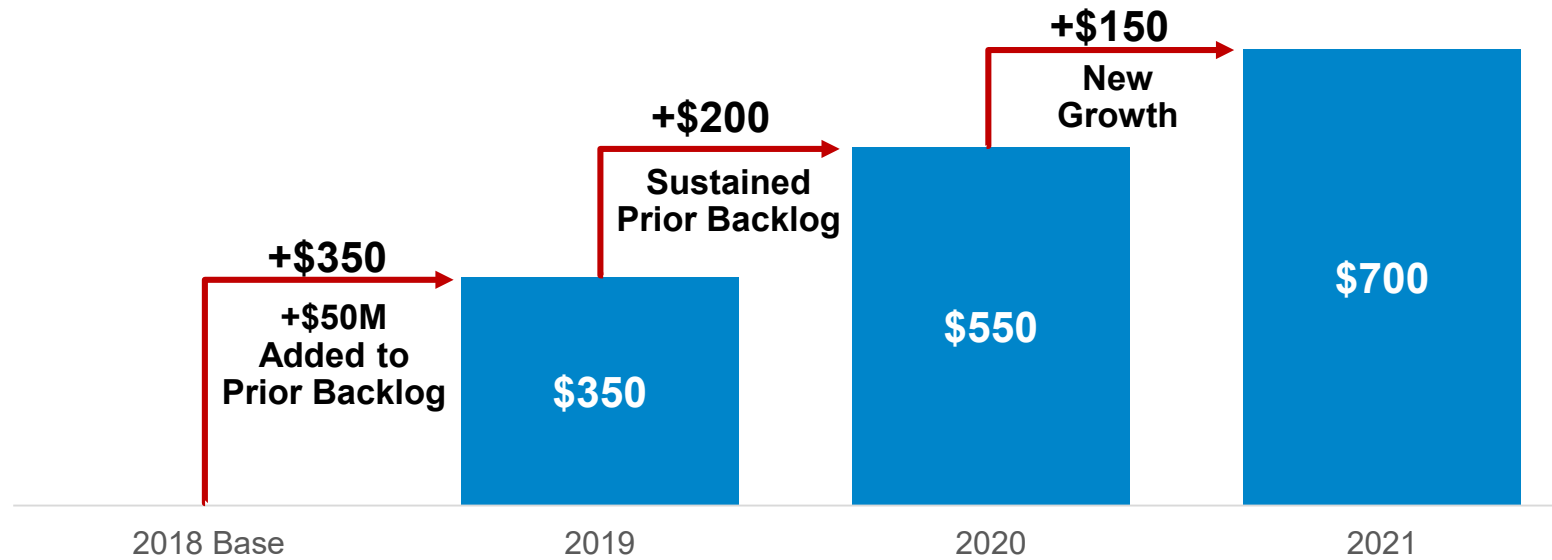

Key Customers



Backlog ensures outperformance of market through 2021



2019 Mobility Market Demand Outlook



Mobility Market	Primary Source	Core Segments	Sales Dist ¹	North America	Europe & Africa	South America	Asia Pacific	Dana Impact
				46%	28%	6%	20%	100%
		Full Frame	51%	↘	↑	↑	↑	→
		Medium Duty	28%	↘	↑	↗	↑	↘
		Heavy Duty		↑	→	→	↓	→
		Agriculture	21%	↗	↗	↓	↗	↗
		Construction		↗	↑	↑	↗	↗
		Mining		→	→	→	↗	→
Dana Impact			100%	→	↗	↗	→	→

Legend: YoY Δ

- ↑ >+3%
- ↗ <+3%
- Flat
- ↘ >(3%)
- ↓ <(3%)



¹2018 preliminary sales including 100% of DDAC



2019 Guidance Ranges

- » Guidance reflects existing Dana business and represents ~\$250M or 3% organic growth, ~\$65M of profit growth, 40 bps of profit margin expansion, 100 bps of free cash flow margin expansion, and ~\$0.20 or 7% EPS growth
- » Guidance range with Oerlikon Drive Systems (ODS) reflects 10 months of activity and assumes a March 1st close
- » Guidance with ODS represents ~\$1B or 12% sales growth, ~\$165M of profit growth, 50 bps of profit margin expansion, and ~\$0.30 or 10% EPS growth
- » ODS is expected to be a use of cash in 2019 as transaction costs and integration expenses are included in FCF

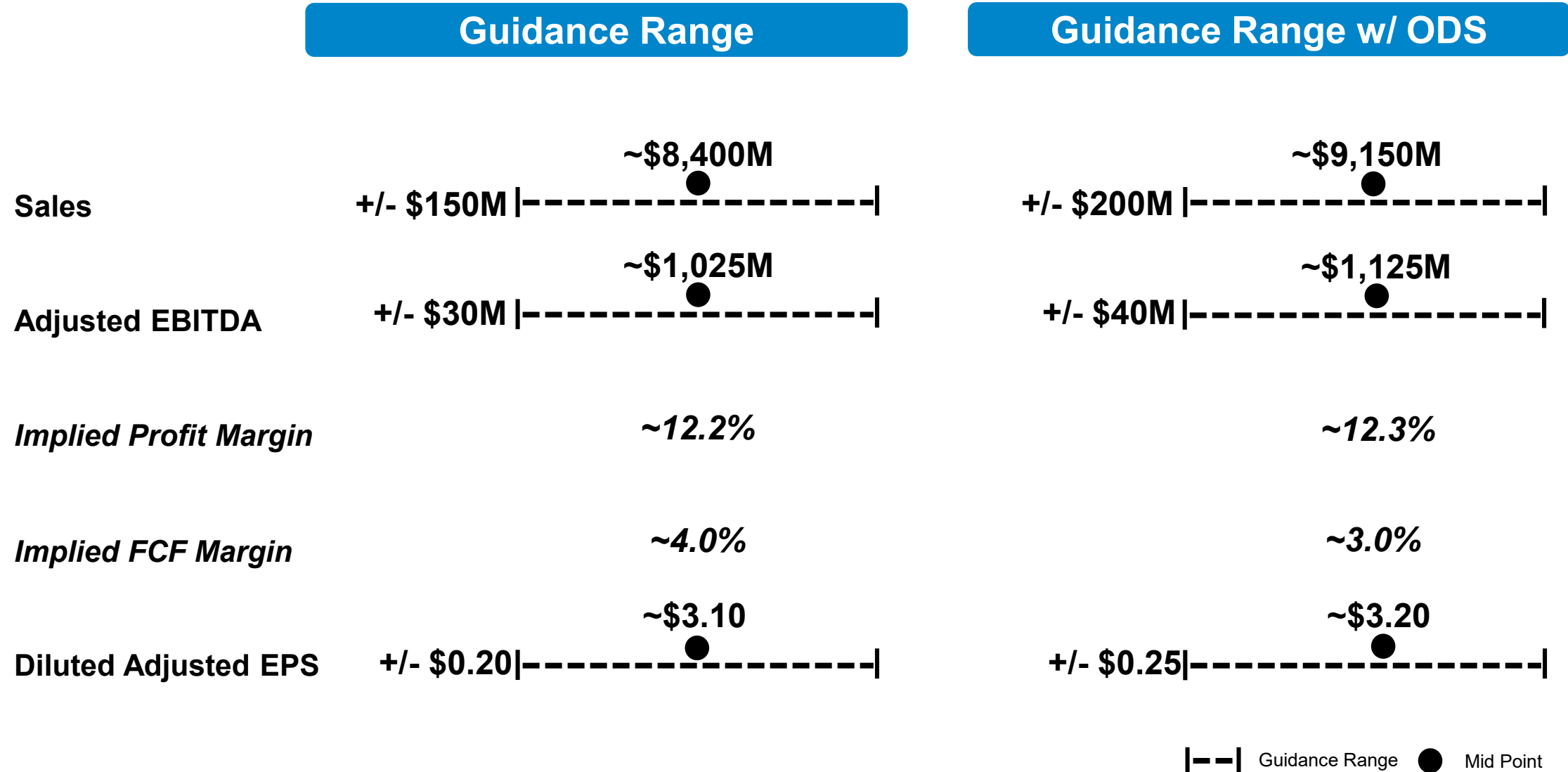

Expecting 3rd year of double digit sales, profit, and FCF growth



2019 Sales and Profit Changes

- Higher conversion on organic growth due to efficiency improvements as well as the benefit of structural costs actions taken in H2 of 2018
- Overlap of Jeep Wrangler program during H1 2018 resulting in ~\$110M of non-recurring sales, contribution margin loss offset by the elimination of launch costs incurred in 2018
- ODS is expected to accrete ~\$100M of profit (10 mo.) including ~\$10M of cost synergies
- Foreign currency expected to provide modest headwind primarily due to EUR/USD
- Commodities costs expected to remain higher than prior year average albeit with higher recovery ratio than prior year as costs plateau

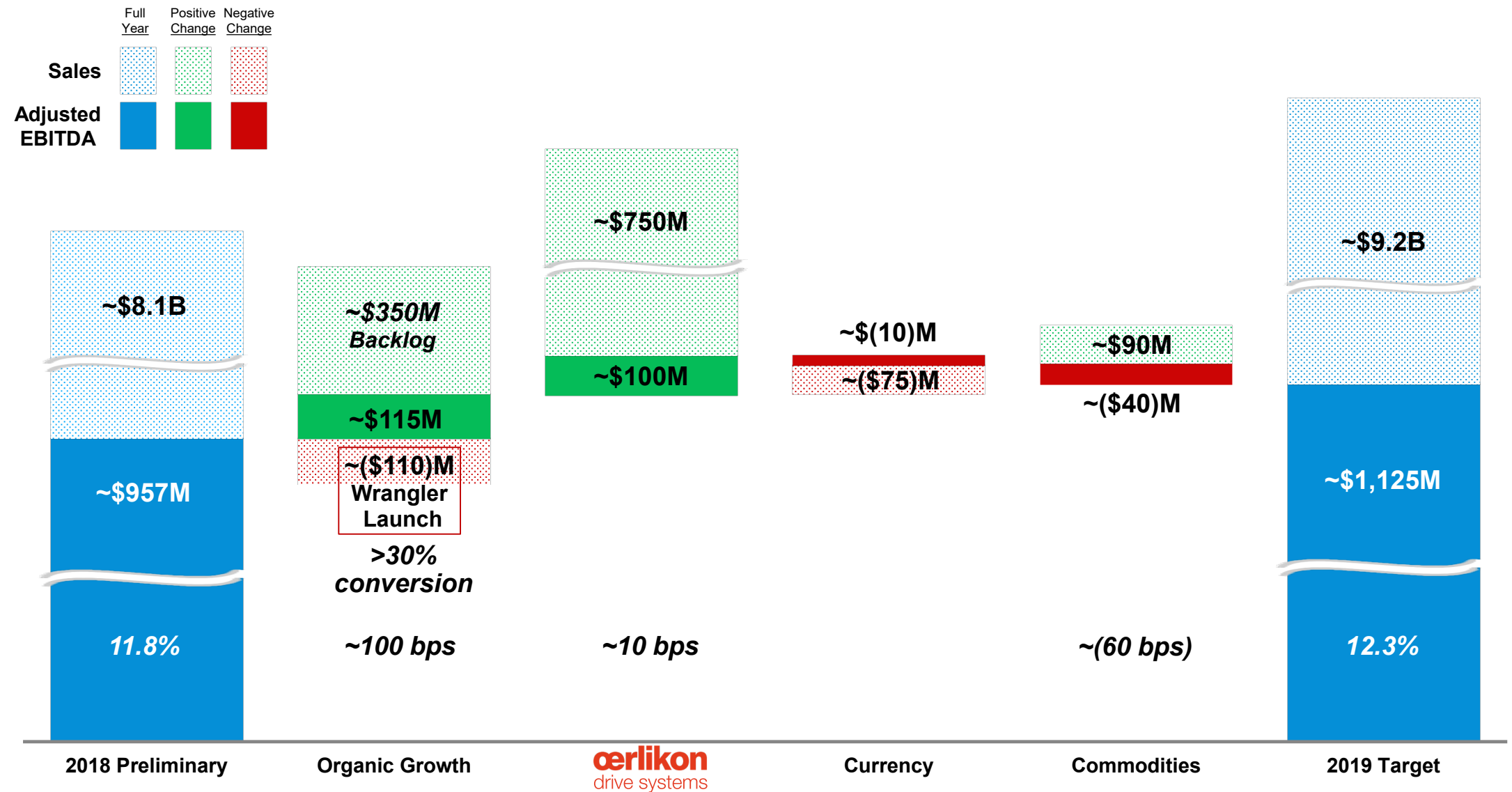

Poised to deliver \$1B of sales growth and add \$165M of profit





Key Financial Metrics Trends

Sales

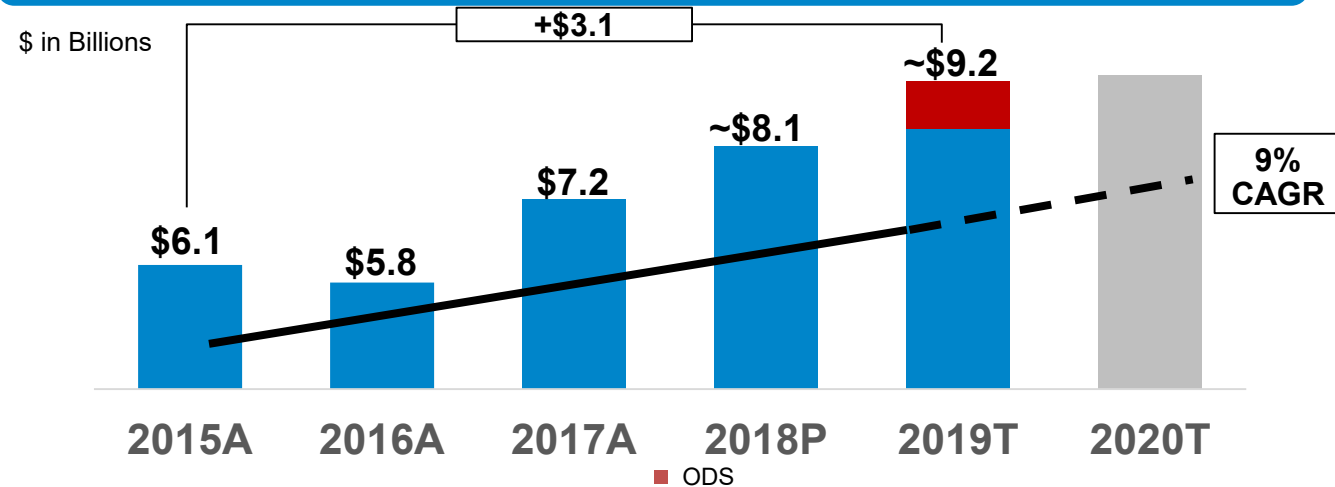

Adjusted EBITDA

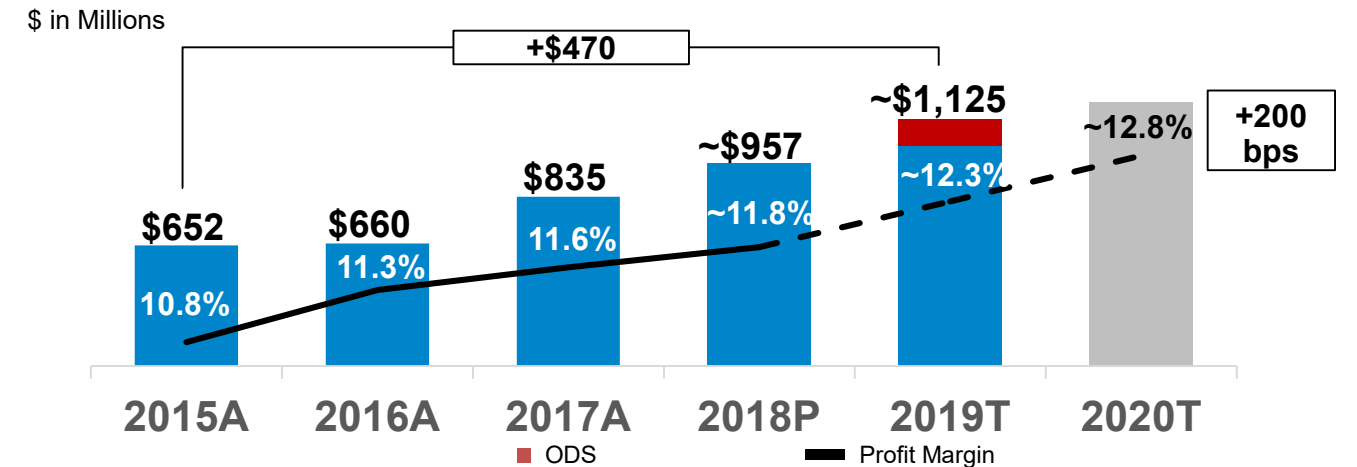

Free Cash Flow

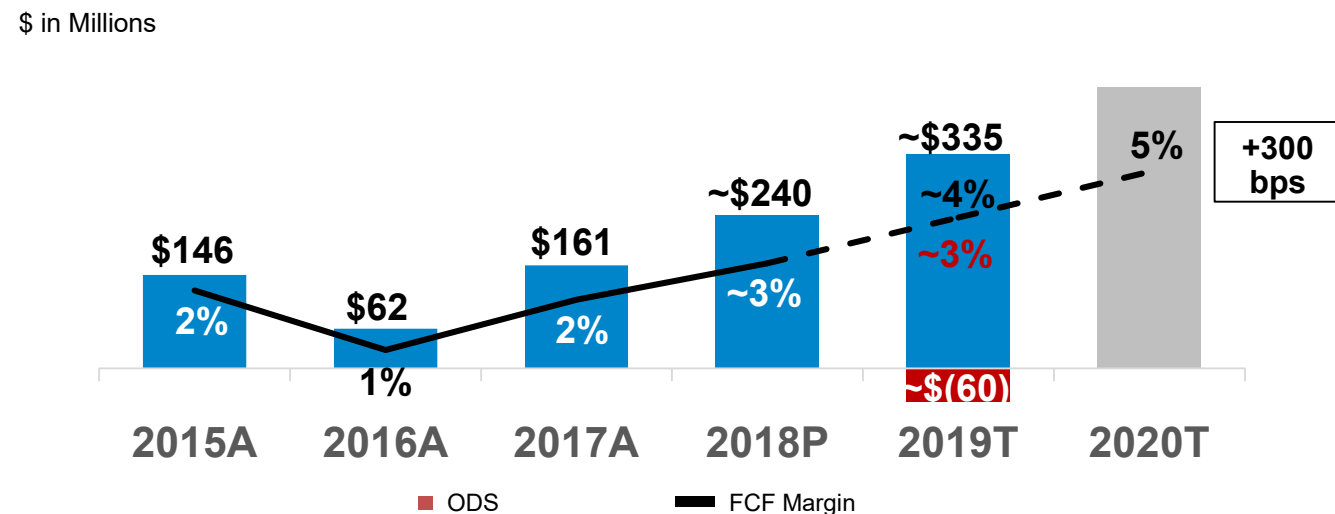

Diluted Adjusted EPS

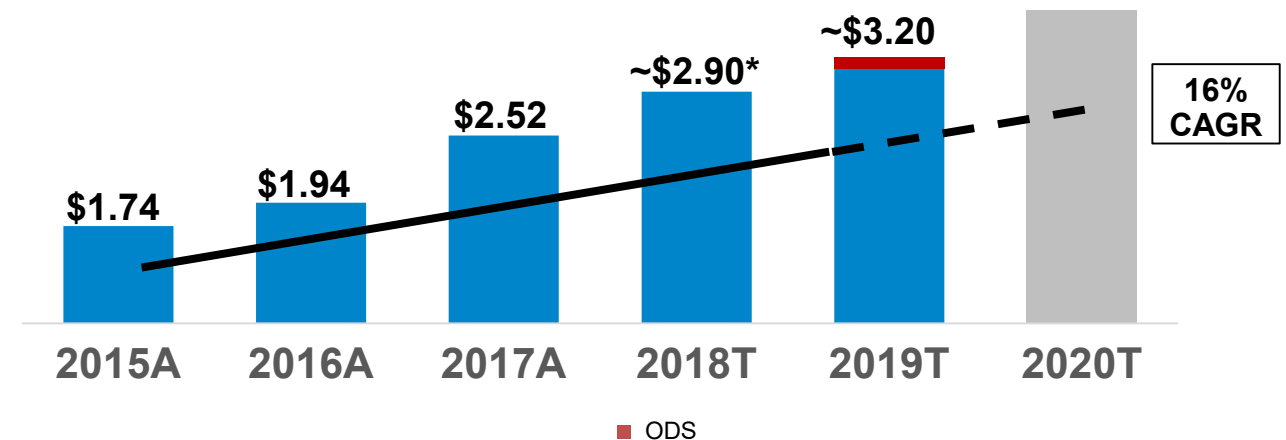

2019 FCF excludes pension termination impact

*As presented in the third quarter 2018 earnings release.

A=Actual; P=Preliminary T=Target



Strong Balance Sheet

Pro Forma Capitalization

(\$ in millions)	YE 2018 Preliminary	YE 2019 Pro forma
Cash and Marketable Securities	~\$525	~\$575
Revolver	~575	~725
Liquidity	~\$1,100	~\$1,300
Term Loan A	~\$265	~\$460
Term Loan B		~445
Senior Notes	~1,500	~1,500
Other Debt	~20	~50
Total Debt	~\$1,785	~\$2,455
Net Debt	~\$1,260	~\$1,880
Adjusted EBITDA	~\$957	~\$1,125
Net Leverage	~1.3x	~1.7x

Maturity Profile

\$ in Millions

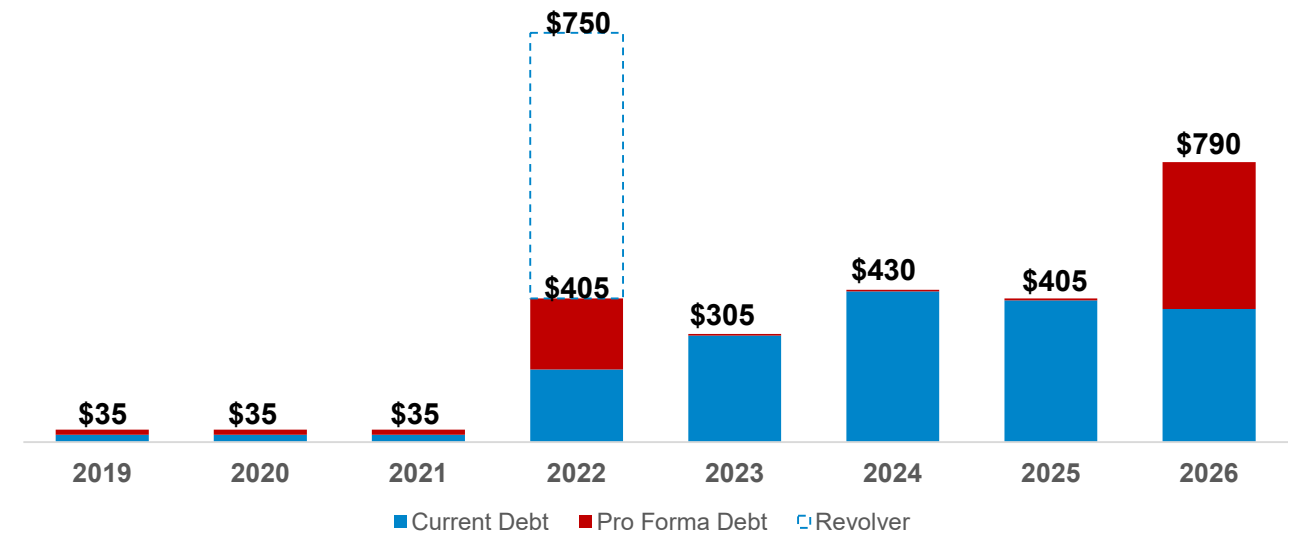

- » No maturities in the next three years
- » Net leverage projected to increase by < 1/2 a turn with ODS acquisition
- » Liquidity to increase by ~\$200M

See appendix for comments regarding the presentation of non-GAAP measures





Capital Allocation Priorities

- » Capital expenditures have normalized at ~4% of sales as largest program have refreshed (i.e. Ford Super Duty and Jeep Wrangler)
- » Disciplined M&A process continues to deliver accretive acquisitions position for long term growth prospects related to vehicle electrification
- » As free cash flows continues to increase, excess cash will be used to further strengthen the balance sheet

1 Organic Growth

- » Investing to deliver backlog generates attractive returns
- » Targeting consistent capital spend levels at ~4% of sales

2 Inorganic Growth

- » Expand product technology
- » Enhance geographic presence

3 Capital Structure

- » Reduce debt and pension liabilities (U.S. frozen pension plan fund and termination planned for 2019)
- » Drive towards investment grade credit metrics

4 Cash Repatriation

- » Pay competitive dividend
- » Ambient level of share repurchase to mitigate dilution; \$200M authorized (\$175M remaining for 2019)

Investing in growth and further strengthening balance sheet





Non-GAAP Financial Information

The preceding slides refer to Adjusted EBITDA, a non-GAAP financial measure which we have defined as net income before interest, taxes, depreciation, amortization, equity grant expense, restructuring expense and, non-service cost components of pension and other postretirement benefits (OPEB) cost and other adjustments not related to our core operations (gain/loss on debt extinguishment, pension settlements, divestitures, impairment, etc.). Adjusted EBITDA is a measure of our ability to maintain and continue to invest in our operations and provide shareholder returns. We use adjusted EBITDA in assessing the effectiveness of our business strategies, evaluating and pricing potential acquisitions and as a factor in making incentive compensation decisions. In addition to its use by management, we also believe adjusted EBITDA is a measure widely used by securities analysts, investors and others to evaluate financial performance of our company relative to other Tier 1 automotive suppliers. Adjusted EBITDA should not be considered a substitute for income before income taxes, net income or other results reported in accordance with GAAP. Adjusted EBITDA may not be comparable to similarly titled measures reported by other companies.

Diluted adjusted EPS is a non-GAAP financial measure which we have defined as adjusted net income divided by adjusted diluted shares. We define adjusted net income as net income attributable to the parent company, excluding any nonrecurring income tax items, restructuring charges, amortization expense and other adjustments not related to our core operations (as used in adjusted EBITDA), net of any associated income tax effects. We define adjusted diluted shares as diluted shares as determined in accordance with GAAP based on adjusted net income. This measure is considered useful for purposes of providing investors, analysts and other interested parties with an indicator of ongoing financial performance that provides enhanced comparability to EPS reported by other companies. Diluted adjusted EPS is neither intended to represent nor be an alternative measure to diluted EPS reported under GAAP.

Free cash flow is a non-GAAP financial measure which we have defined as net cash provided by (used in) operating activities excluding voluntary pension contributions, less purchases of property, plant and equipment. We believe this measure is useful to investors in evaluating the operational cash flow of the company inclusive of the spending required to maintain the operations. Free cash flow is neither intended to represent nor be an alternative to the measure of net cash provided by (used in) operating activities reported under GAAP. Free cash flow may not be comparable to similarly titled measures reported by other companies.

Please reference the “Non-GAAP financial information” accompanying our quarterly earnings conference call presentations on our website at www.dana.com/investors for reconciliations of adjusted EBITDA, diluted adjusted EPS and free cash flow to the most directly comparable financial measures calculated and presented in accordance with GAAP. We have not provided a reconciliation of our adjusted EBITDA and diluted adjusted EPS outlook to the most comparable GAAP measures of net income and diluted EPS. Providing net income and diluted EPS guidance is potentially misleading and not practical given the difficulty of projecting event driven transactional and other non-core operating items that are included in net income and diluted EPS, including restructuring actions, asset impairments and income tax valuation adjustments. The reconciliations of these non-GAAP measures with the most comparable GAAP measures for the historical periods presented on our website are indicative of the reconciliations that will be prepared upon completion of the periods covered by the non-GAAP guidance.

